

New Hydrogen Technologies and Space Drives, Congress Center Thurgauerhof,
CH-8570 Weinfelden, German Association for Space Energy

Scalar waves

Theory and Experiments

by:

Prof. Dr.-Ing. Konstantin Meyl

Introduction

It will be shown that scalar waves, normally remaining unnoticed, are very interesting in practical use for information and energy technology for reason of their special attributes. The mathematical and physical derivations are supported by practical experiments. The demonstration will show:

1. the wireless transmission of electrical energy,
2. the reaction of the receiver to the transmitter,
3. free energy with an over-unity-effect of about 3,
4. transmission of scalar waves with 1.5 times the speed of light,
5. the inefficiency of a Faraday cage to shield scalar waves.

Tesla radiation

Here is shown extraordinary science, five experiments, which are incompatible with textbook physics. Following my short lecture I will present you the transmission of longitudinal electric waves.

It is a historical experiment, because already 100 years ago the famous experimental physicist Nikola Tesla has measured the same wave properties, as me. From him stems a patent concerning the wireless transmission of energy (1900)¹. Since he also had to find out that at the receiver arrives very much more energy, than the transmitter takes up, he spoke of a „Magnifying Transmitter“.

By the effect back on the transmitter Tesla sees, if he has found the resonance of the earth and that lies according to his measurement at 12 Hz. Since the Schumann resonance of a wave, which goes with the speed of light, however lies at 7.8 Hz, Tesla comes to the conclusion, that his wave has 1.5 times the speed of light².

As founder of the diathermy Tesla already has pointed to the biological effectiveness and to the possible use in medicine. The diathermy of today has nothing to do with the Tesla radiation; it uses the wrong wave and as a consequence hardly has a medical importance.

The discovery of the Tesla radiation is denied and isn't mentioned in the textbooks anymore. For that there are two reasons:

1. No highschool ever has rebuilt a „Magnifying Transmitter“. The technology simply was too costly and too expensive. In that way the results have not been reproduced, as it is imperative for an acknowledgement. I have solved this problem by the use of modern electronics, by replacing the spark gap generator with a function generator and the operation with high-tension with 2-4 Volts low-tension. I sell the experiment as a demonstration-set so that it is reproduced as often as possible. It fits in a case and has been sold more than 100 times. Some universities already could confirm the effects. The measured degrees of effectiveness lie between 140 and 1000 percent.

2. The other reason, why this important discovery could fall into oblivion, is to be seen in the missing of a suitable field description. The Maxwell equations in any case only describe transverse waves, for which the field pointers oscillate perpendicular to the direction of propagation.

Maxwell equations:

$$\text{rot } \mathbf{E} = - \delta \mathbf{B} / \delta t \qquad \text{rot } \mathbf{H} = \mathbf{j} + \delta \mathbf{D} / \delta t$$
$$\mathbf{B} = \mu \cdot \mathbf{H} \qquad \mathbf{j} = 0 \qquad \mathbf{D} = \epsilon \cdot \mathbf{E}$$
$$\text{rot rot } \mathbf{E} = - \mu \cdot \delta (\text{rot } \mathbf{H} / \delta t) = - \mu \cdot \epsilon \cdot \delta^2 \mathbf{E} / \delta t^2$$
$$\mu \cdot \epsilon = 1 / c^2$$

wave equation:

$$\Delta \mathbf{E} = \underbrace{\text{grad div } \mathbf{E}}_{?} - \text{rot rot } \mathbf{E} = \frac{1}{c^2} \frac{\delta^2 \mathbf{E}}{\delta t^2}$$

Figure 1: The vectorial part of the wave equation (derived from the Maxwell equations)

Wave equation

By using the Laplace operator the well-known wave equation, according to the rules of vector analysis, can be taken apart in two parts: in the vectorial part (rot rot \mathbf{E}), which results from the Maxwell equations and in a scalar part (grad div \mathbf{E}), according to which the divergence of a field pointer is a scalar. We have to ask ourselves, which properties has this wave part, which founds a scalar wave?

Laplace-operator	rot $\mathbf{E} = 0$: longitudinal wave	div $\mathbf{E} = 0$: transversal wave	$c =$ speed of light
------------------	---	--	-------------------------

$$\Delta \mathbf{E} = \text{grad div } \mathbf{E} - \text{rot rot } \mathbf{E} = \frac{1}{c^2} \frac{\delta^2 \mathbf{E}}{\delta t^2}$$

Div $\mathbf{E} \neq 0$ is a scalar \Rightarrow scalar wave!

$\mathbf{E} = -\text{grad } \varphi$:

- (1) ~~grad div $\mathbf{E} = -\text{grad} \frac{1}{c^2} \frac{\delta^2 \varphi}{\delta t^2}$~~
- (2) $\text{div } \mathbf{E} = -\text{div grad } \varphi$
- (3) $\text{div } \mathbf{D} = \rho$: $\text{div } \mathbf{E} = \rho/\epsilon$

plasma wave:

$$\Delta \varphi = \frac{1}{c^2} \cdot \frac{\delta^2 \varphi}{\delta t^2} - \frac{\rho}{\epsilon}$$

Figure 2: The scalar part of the wave equation describes longitudinal electric waves (derivation of plasma waves).

If we derive the field vector from a scalar potential ϕ , then this approach immediately leads to an inhomogeneous wave equation, which is called plasma wave. Solutions are known, like the electron plasma waves, which are longitudinal oscillations of the electron density (Langmuir waves).

Vortex model

The Tesla experiment and my historical rebuild however show more. Such longitudinal waves obviously exist even without plasma in the air and even in vacuum. The question thus is asked, what the divergence \mathbf{E} describes in this case? How is the impulse passed on, so that a longitudinal standing wave can form? How should a shock wave come about, if there are no particles which can push each other?

I have solved this question, by extending Maxwell's field theory for vortices of the electric field. These so-called potential vortices are able to form structure and they propagate in space for reason of their particle nature as a longitudinal shock wave. The model concept bases on the ring vortex model of Hermann von Helmholtz, which Lord Kelvin did make popular. In my books³ the mathematical and physical derivation is described.

In spite of the field theoretical set of difficulties every physicist at first will seek for a conventional explanation. He will try two approaches:

Resonant circuit interpretation

Tesla had presented his experiment among others to Lord Kelvin and he already 100 years ago has spoken of a vortex transmission. In the opinion of Kelvin it however by no means concerns a wave but radiation. He had recognized clearly, that every radio technical interpretation had to fail, because alone the course of the field lines is a completely different one.

It presents itself to assume a resonant circuit, consisting of a capacitor and an inductance.

1. closed resonant circuit

resonance frequency:

$$f = \frac{1}{2\pi\sqrt{LC}}$$

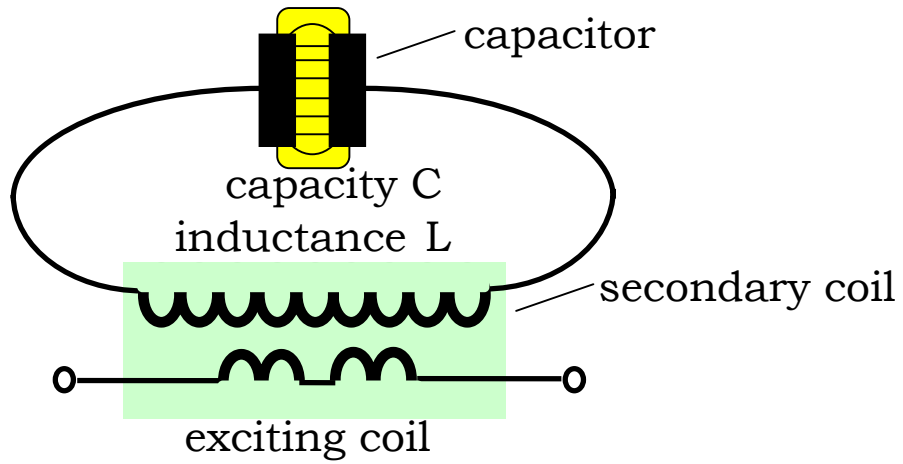

2. separating the resonant circuit

Field lines of the electrical fieldstrength:

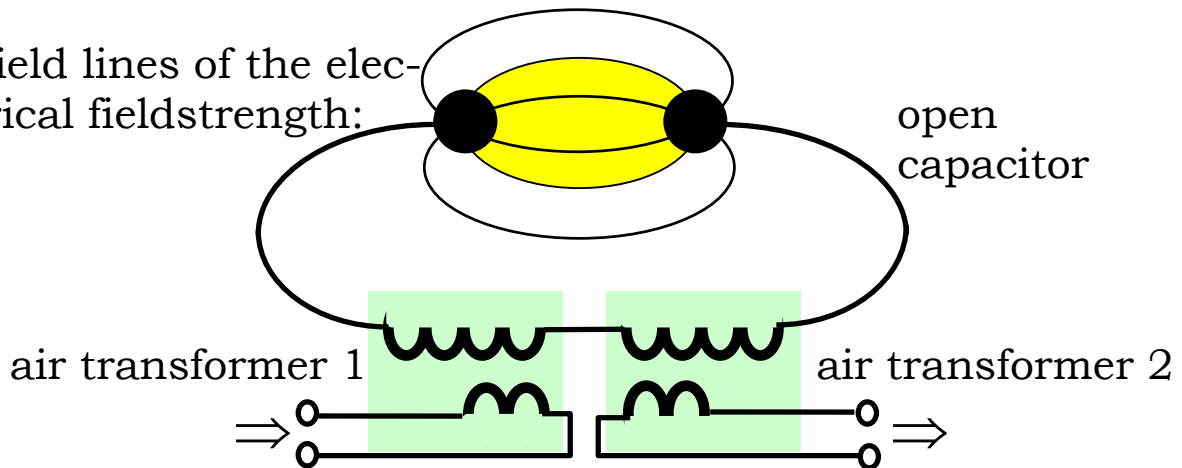

3. resonant circuit with open capacitor

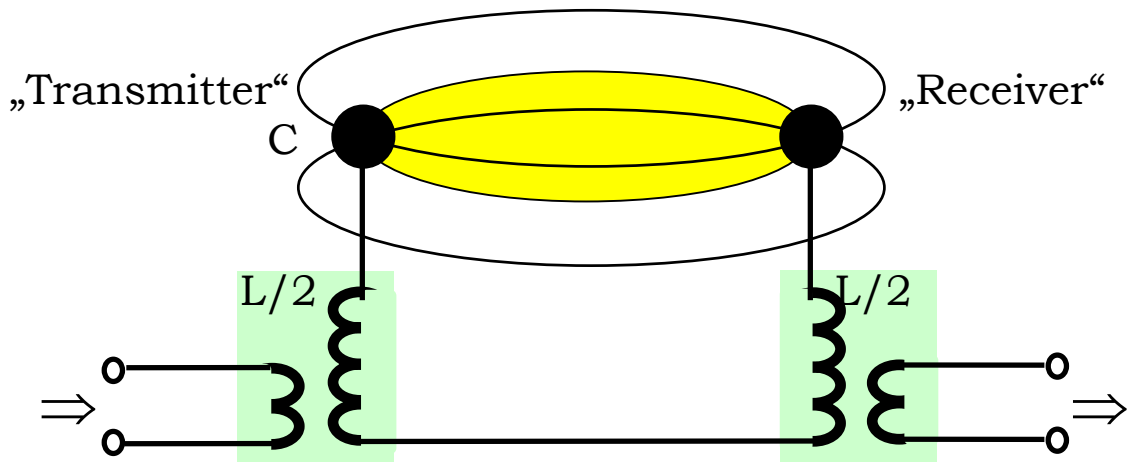

Figure 3: Interpretation as an open resonant circuit

If both electrodes of the capacitor are pulled apart, then between both is stretching an electric field. The field lines start at one sphere, the transmitter, and they bundle up again at the receiver. In that way a higher degree of effectiveness and a very tight coupling can be expected. In this manner without doubt some of the effects can be explained, but not all.

The inductance is split up in two air transformers, which are wound completely identical. If a fed in sinusoidal tension voltage is transformed up in the transmitter, then it is again transformed down at the receiver. The output voltage should be smaller or at maximum equal the input voltage – but it is substantially bigger!

There can be drawn and calculated an alternative wiring diagram, but in no case the measurable result comes out, that light-emitting diodes at the receiver glow brightly ($U > 2\text{Volt}$), whereas at the same time the corresponding light-emitting diodes at the transmitter go out ($U < 2\text{Volt}$)! To check this both coils are exchanged.

The measured degree of effectiveness lies despite the exchange at 1000 percent. If the law of conservation of energy should not be violated, then only one interpretation is left: The open capacitor withdraws field energy from its environment. Without consideration of this circumstance does the error deviation of every conventional model calculation lie at more than 90 percent. There one rather should do without the calculation.

It will concern oscillating fields, because the spherical electrodes are changing in polarity with a frequency of approx. 7 MHz. They are operated in resonance. The condition for resonance reads: identical frequency and opposite phase. The transmitter obviously modulates the field in its environment, while the receiver collects everything what fulfils the condition for resonance.

Also in the open question for the transmission velocity of the signal the resonant circuit interpretation fails. But the HF-technician still has another explanation at the tip of his tongue:

Near field interpretation

In the near field of an antenna effects are measured, which on the one hand go as inexplicable, because they evade the normally used field theory, which on the other hand come the by me shown scalar wave effects very close. Everyone knows a practical application: e.g. at the entrance of department stores, where the customer has to go through in between of scalar wave detectors.

In my experiment the transmitter is situated in the mysterious near zone. Also Tesla always worked in the near zone. But who asks for the reasons, will discover that the near field effect is nothing else but the scalar wave part of the wave equation. My explanation goes as follows:

The charge carriers which oscillate with high-frequency in an antenna rod form longitudinal standing waves. As a result also the fields in the near zone of a Hertzian dipole are longitudinal scalar wave fields. The picture shows clearly how vortices are forming and how they come off the dipole.

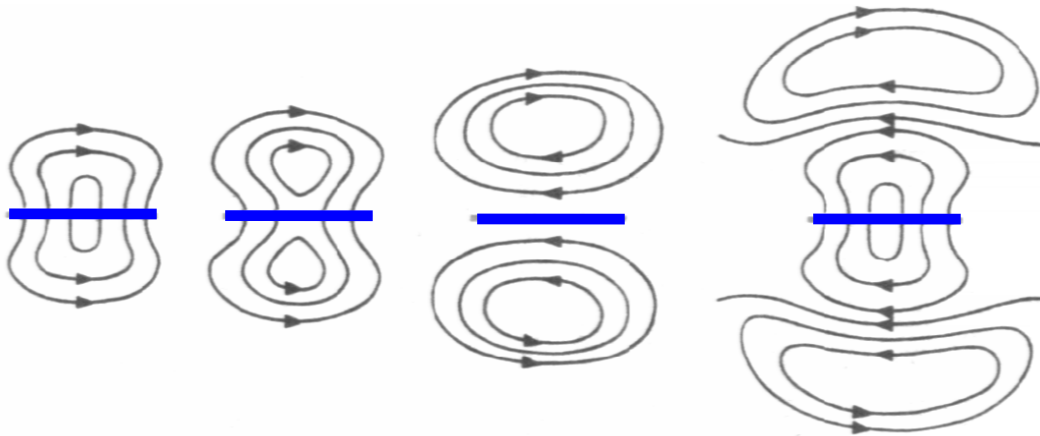

Figure 4: The coming off of the electric field lines of the dipole.

Like for the charge carriers in the antenna rod the phase angle between current and tension voltage amounts to 90 degrees, occur in the near field also the electric and the magnetic field phase shifted for 90 degrees. In the far field however the phase angle is zero. In my interpretation the vortices are breaking up, they decay, and transverse radio waves are formed.

Vortex interpretation

The vortex decay however depends on the velocity of propagation. Calculated at the speed of light the vortices already have decayed within half the wavelength. The faster the velocity, the more stable they get, to remain stable above 1.6 times the velocity. These very fast vortices contract in the dimensions. They now can tunnel. Therefore speed faster than light occurs at the tunnel effect. Therefore no Faraday cage is able to shield fast vortices.

Since these field vortices with particle nature following the high-frequency oscillation permanently change their polarity from positive to negative and back, they don't have a charge on the average over time. As a result they almost unhindered penetrate solids. Particles with this property are called neutrinos in physics. The field energy which is collected in my experiment, according to that stems from the neutrino radiation which surrounds us. Because the source of this radiation, all the same if the origin is artificial or natural, is far away of my receiver, every attempt of a near field interpretation goes wrong. After all does the transmitter installed in the near field zone supply less than 10% of the received power. The 90% however, which it concerns here, cannot stem from the near field zone!

Experiment

At the function generator I adjust frequency and amplitude of the sinusoidal signal, with which the transmitter is operated. At the frequency regulator I turn so long, till the light-emitting diodes at the receiver glow brightly, whereas those at the transmitter go out. Now an energy transmission takes place.

If the amplitude is reduced so far, till it is guaranteed that no surplus energy is radiated, then in addition a gain of energy takes place by energy amplification.

If I take down the receiver by pulling out the earthing, then the lighting up of the LED's signals the mentioned effect back on the transmitter. The transmitter thus feels, if its signal is received.

The self-resonance of the Tesla coils, according to the frequency counter, lies at 7 MHz. Now the frequency is ran down and see there, at approx. 4.7 MHz the receiver again glows, but less bright, easily shieldable and without discernible effect back on the transmitter. Now we unambiguously are dealing with the transmission of the Hertzian part and that goes with the speed of light. Since the wavelength was not changed, does the proportion of the frequencies determine the

proportion of the velocities of propagation. The scalar wave according to that goes with $(7/4.7=)$ 1.5 times the speed of light!

If I put the transmitter into the aluminium case and close the door, then nothing should arrive at the receiver. Expert laboratories for electromagnetic compatibility in this case indeed cannot detect anything and that, although in spite of that the receiver lamps glow! By turning of the receiver coil it can be verified that an electric and not a magnetic coupling is present although the Faraday cage should shield electric fields. The scalar wave obviously overcomes the cage with a speed faster than light, by tunnelling!

Literature

- 1 Nikola Tesla: Apparatus for transmission of electrical energy.
US-Patent No. 645,576, N.Y. 20.3.1900.
- 2 Nikola Tesla: Art of transmitting electrical energy through the natural mediums, US-Patent No. 787,412, N.Y. 18.4.1905.
- 3 Konstantin Meyl: Elektromagnetische Umweltverträglichkeit,
Teil 1: Umdruck zur Vorlesung, Villingen-Schwenningen 1996, 3.Aufl. 1998
Teil 2: Energietechnisches Seminar 1998, 3. Auflage 1999,
Teil 3: Informationstechnisches Seminar 2002, auszugsweise enthalten in:
K. Meyl: Skalarwellentechnik, Dokumentation für das Demonstrations-Set,
INDEL-Verlag, Villingen-Schwenningen,
will be translated till 2002 :
- 3 Konstantin Meyl: Scalar Waves, INDEL-Verlag.
(see: <http://www.k-meyl.de>).

Address:

Prof. Dr.-Ing. Konstantin Meyl,
1.TZS (First Transfer Center of Scalar Wave Technology)
Leopoldstraße 1,
D-78112 St. Georgen/Schwarzwald (Germany)
Tel.: 0049-/0- 7724-1770, Fax.: 0049-/0- 7724-9486720
Email: meyl@k-meyl.de

- More information in the internet: <http://www.k-meyl.de>